

TC/TCM
Two Stage Liquid Ring Vacuum Pumps



NASH TC/TCM Two Stage Vacuum Pumps

Industry Workhorses

NASH liquid ring vacuum pumps produced by Gardner Denver Nash have been known for more than 100 years as tireless workhorses, designed to stand up to the rigorous, nonstop demands of the harshest industrial environments. Built better than industry standards, NASH pumps are known for their reliability.

The TC/TCM pumps are manufactured to ISO 9001:2000 standards and are ATEX compliant. Our commitment to excellence and customer service extends from manufacturing and installation to technical assistance and beyond. Service and distribution centers are located throughout the world, offering quality service and support for Nash products.

Features	Benefits
New, patented air/water separation design*	Improved efficiency
Integrated Two Stage Design	Improved system performance and efficiency
Accepts single, double and cartridge mechanical seals	Flexibility, to meet your process requirements
V-belt or flexible coupling drive	Numerous installation options
Integral two stage impeller	High reliability, can attain high vacuum without additional components
Shrouded rotor blades	Strength and reliability
Removable bearing bracket	Easier maintenance
O ring and gasket sealing options**	Optimum sealing to your specs
ATEX compliant	Meets today's industry standards
ISO & ANSI connections available	Meets global requirements
Offered in ductile iron or in stainless steel	High durability and corrosion resistance
9 models	Flexibility, to meet your process requirements
100% performance tested	Trouble-free start-up and operation
Backed by 2 year warranty and over 100 years of vacuum and compressed gas experience	Peace of mind

Vacuum technology

The TC/TCM liquid ring vacuum pumps were created for the chemical, petrochemical and power industries as well as other high vacuum applications. They are designed to operate at very low suction pressure levels (less than 10 torr) with low vapor pressure seal liquids. In many applications, this translates into considerable operational savings by reducing the number of stages on hybrid systems. For example, a three stage jet system with glycol as motive and seal liquid can be reduced to a two stage system.

These pumps, with their integral two stage rotors, are able to condense process vapors and to recover or dispose of them. The result is a highly reliable and efficient vacuum pump.

Basic specifications	
Vacuum range	down to 0.8 in HgA (27 mbar)
Mechanical seals	Single, double or cartridge
Hydrotest pressure (ductile iron pumps)	75 psig (6 bar abs) standard
Hydrotest pressure (stainless steel pumps)	150 psig (12 bar abs) standard
Capacity range	100 to 2,200 CFM (170 to 3740 m ³ /h)
Construction material	Ductile iron or stainless steel



*TC 8, TC 9, TC 10 and TC 11 only

**TC 8, TC 9 and TC 10 only

NASH TC/TCM Two Stage Vacuum Pumps

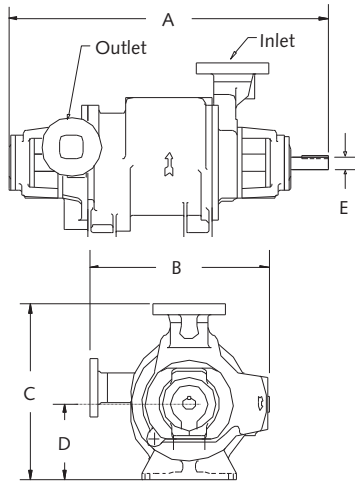

TCM 1-3, TC 5

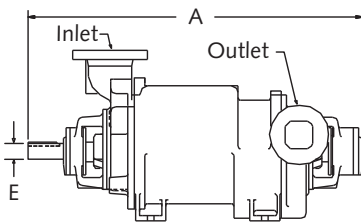

TC 7 - 11

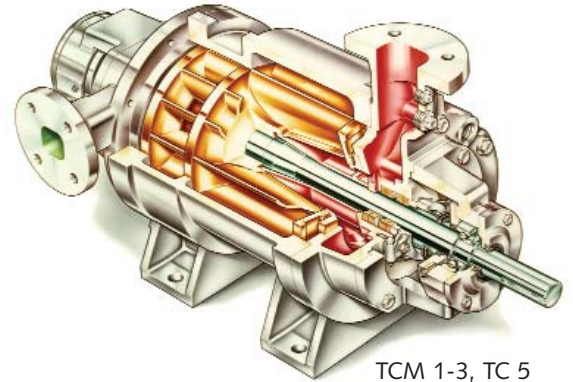

TCM 1-3, TC 5

Dimensions inch/mm

Pump	A	B	C	D	E	Inlet	Outlet
TCM 1	31.1 791	15.6 397	15.5 394	6.5 165	1.4 35	2 in. FLG 50 mm FLG	2 in. FLG 50 mm FLG
TCM 2	36.9 937	17.1 435	17.8 451	7.9 200	1.5 38	2 in. FLG 50 mm FLG	2 in. FLG 50 mm FLG
TCM 3	38.6 981	17.1 435	17.8 451	7.9 200	1.5 38	2 in. FLG 50 mm FLG	2 in. FLG 50 mm FLG
TC 5	40.3 1022	22.5 572	22 559	9.5 241	1.6 41	4 in. FLG 100 mm FLG	3 in. FLG 80 mm FLG
TC 7	51 1282	28 702	26 654	13 330	2.4 60	6 in. FLG 150 mm FLG	4 in. FLG 100 mm FLG
TC 8	61.1 1552	33.3 846	29 737	14 356	3.15 80	6 in. FLG 150 mm FLG	4 in. FLG 100 mm FLG
TC 9	73.3 1862	41.6 1056	35 890	17 432	3.34 85	8 in. FLG 200 mm FLG	6 in. FLG 150 mm FLG
TC 10	76.4 1942	44.6 1132	37 940	18 457	3.35 85	8 in. FLG 200 mm FLG	6 in. FLG 150 mm FLG
TC 11	81 2060	40 1005	43 1080	19 480	3.7 95	8 in. FLG 200 mm FLG	6 in. FLG 150 mm FLG

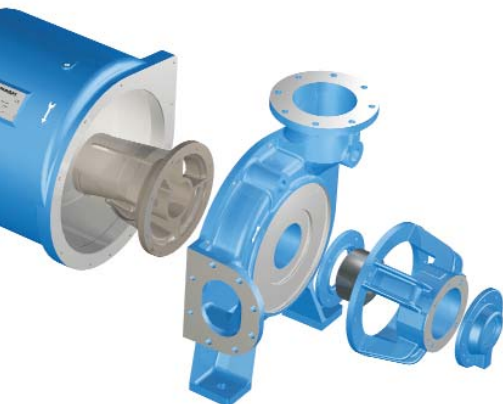

TC 8 Exploded View

Performance

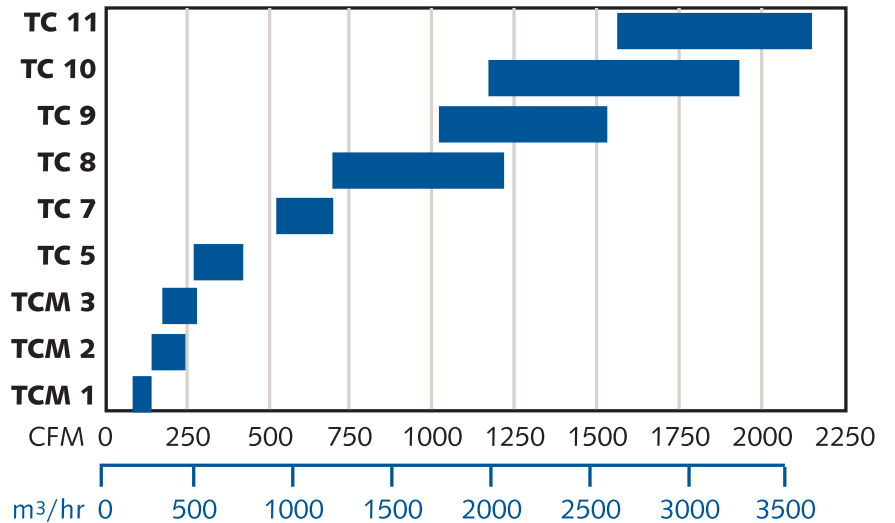

Other NASH Products

2BV Compact liquid ring vacuum pumps built for serious cost savings
Use up to 50 percent less water than other liquid ring pumps
Monoblock and pedestal designs available
Capacity of 4 to 350 CFM with vacuum to 29+'' HgV
Capacity of 7 to 595 m³/h with vacuum to 33 mbar abs



Service We have the know-how, the expertise and the specialists. We provide professional service to make your pumps run for decades. Our service centers are located in:

- Australia
- Brazil
- China
- France
- Germany
- Korea
- Netherlands
- Singapore
- South Africa
- Sweden
- UK
- USA



2BE3/P2620 Large liquid ring vacuum pumps with superior corrosion resistance
Top discharge capability which eliminates need for trench
Self-recirculating seal water, reducing need for external seal water source
Capacity of 4,000 to 23,000 CFM with vacuum to 24'' HgV
Capacity of 6,800 to 39,000 m³/h with vacuum to 200 mbar abs



Vectra Liquid ring vacuum pumps and compressors
Available in feature rich budget designs (XL or GL)
Designed to handle high back pressure requirements
Capacity of 115 to 2,860 CFM with vacuum to 29+'' HgV
Capacity of 195 to 4,860 m³/h with vacuum to 31 mbar abs



Compressors Wide range of liquid ring compressors designed for many applications. Rugged and reliable, they can handle highly toxic, explosive and corrosive gases. Specifically developed for applications such as flare-gas, Chlorine and Vinyl Chlorine Monomer (VCM) recovery
Capacity of 60 to 2,200 SCFM with pressure to 200 PSIG
Capacity of 100 to 3,740 m³/h with pressure to 15 bar abs
Single and two stage models available

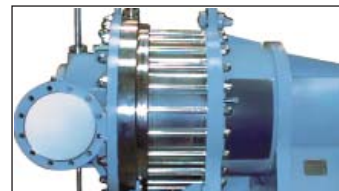

Gardner Denver Nash has many ISO 9001 certifications.



**Gardner Denver Nash
Deutschland GmbH**
Katzwanger Straße 150
90461 Nuremberg, Germany
phone: +49 911 1454-0
fax: +49 911 1454-6935
nash@de.gardnerdenver.com
GDNash.com

**Gardner Denver
Engineered Products Division**
9 Trefoil Drive
Trumbull, CT 06611, USA
phone: +1 203 459 3900
fax: +1 203 459 3988
nash@gardnerdenver.com
GDNash.com